

NOTE
 ALL DIMENSIONS TO BE CHECKED ON SITE
 NO DIMENSIONS TO BE SCALED FROM THIS DRAWING
 THIS DRAWING IS TO BE READ IN CONJUNCTION WITH
 RELEVANT CONSULTANTS DRAWINGS
 NO PART OF THIS DOCUMENT MAY BE REPRODUCED OR
 TRANSMITTED IN ANY FORM OR STORED IN ANY RETRIEVAL
 SYSTEM OF ANY NATURE WITHOUT THE WRITTEN PERMISSION
 OF THE LANDSCAPE ARCHITECT AS COPYRIGHT HOLDER EXCEPT
 AS AGREED FOR USE ON THE PROJECT FOR WHICH THE
 DOCUMENT WAS ORIGINALLY ISSUED.
 FOR DRAWING INDEX, GENERAL NOTES, REFER TO
 DWG L1-001

CLIENT:
Sandyford Environmental Construction Limited

ARCHITECTS:

01 MAGNETIC BELLS REFERENCE IMAGE
 1:25

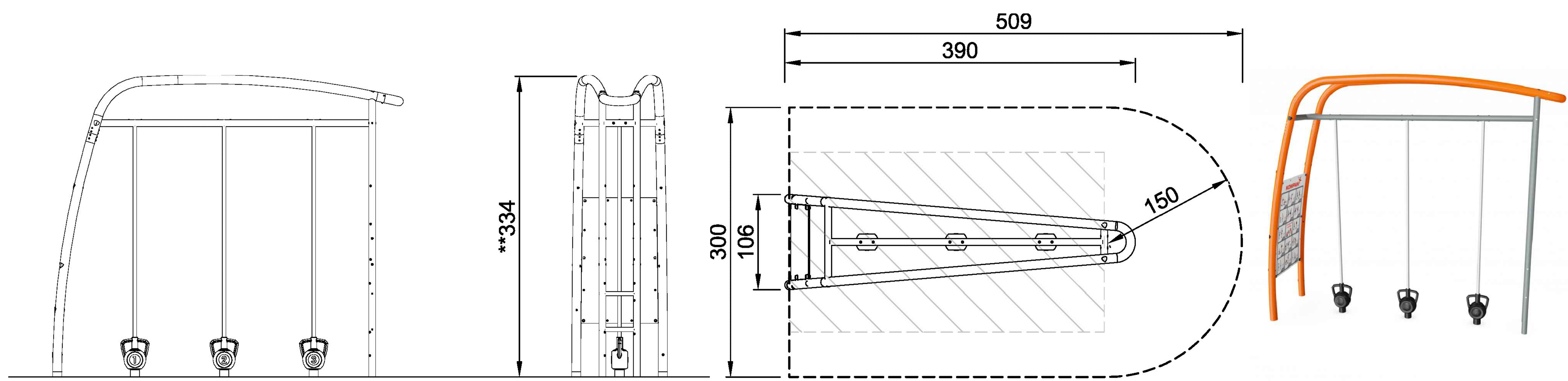

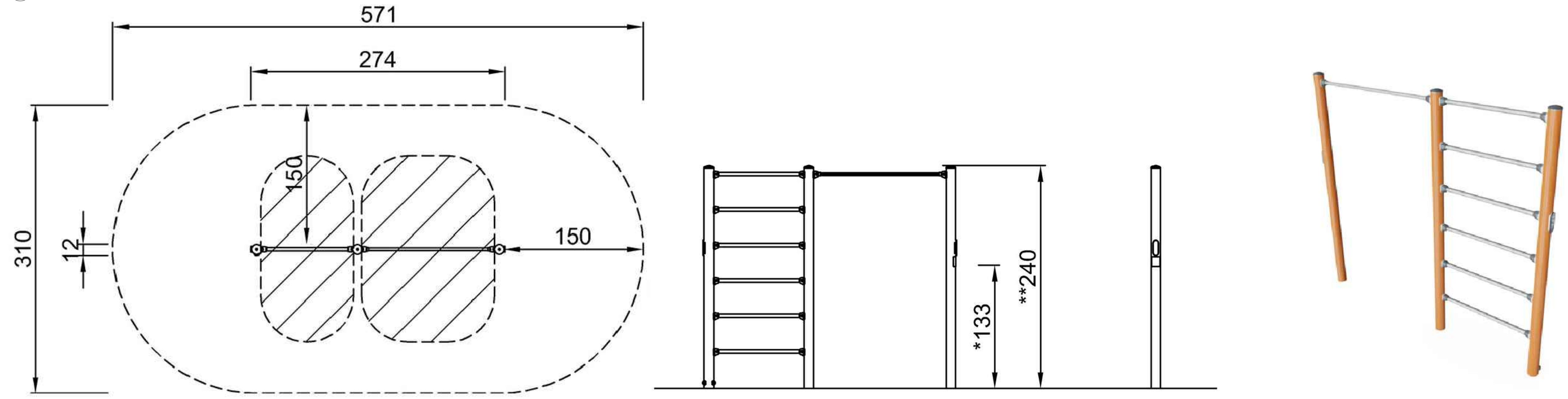
02 PULL UP BARS REFERENCE IMAGE
 1:25

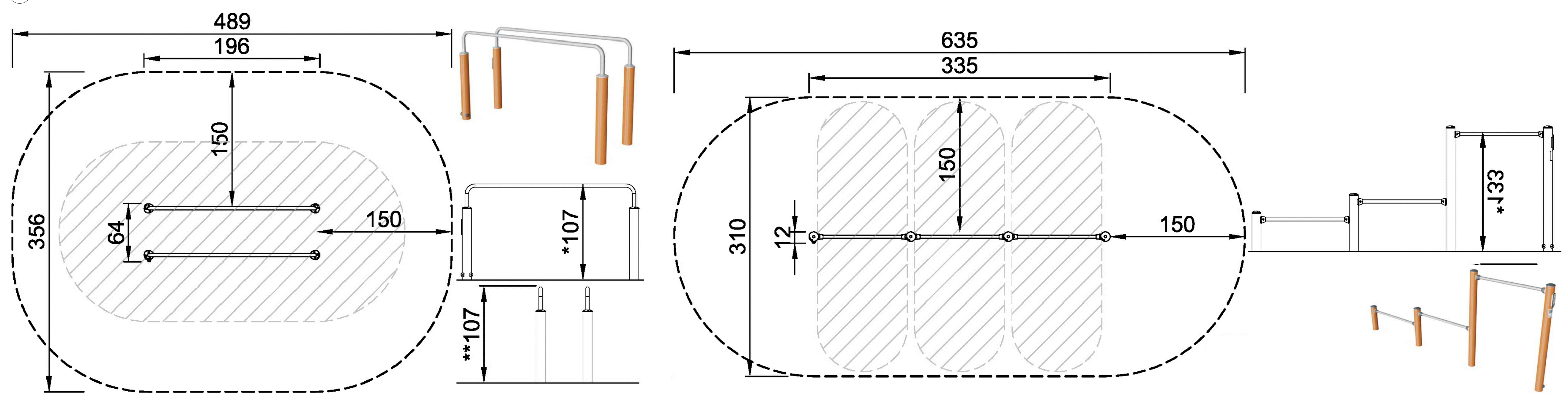

03 PARALLEL BARS REFERENCE IMAGE
 1:25

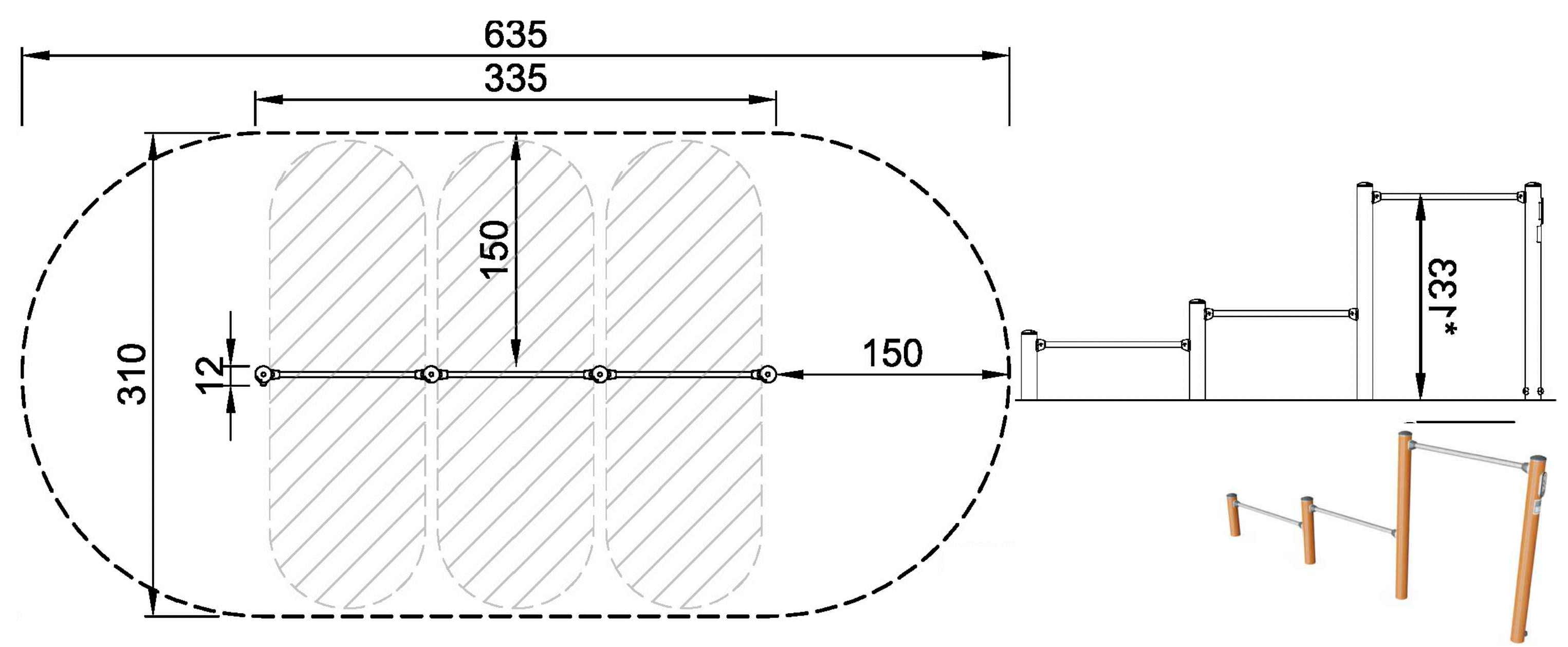

04 PUSH UP BARS REFERENCE IMAGE
 1:25

REVISIONS			
Job No.	18ASA	Drawn By	LB
Dwg No.	T-L1-905	Checked By	JM
Scale	N/A @A1	Date	MARCH 2022

JOB DESCRIPTION	
Site	RAVENS ROCK ROAD
Project	TACK SANDYFORD SHD
Title	OUTDOOR EXERCISE EQUIPMENT